

MAXIM

MAX8536 Evaluation Kit

Evaluates: MAX8536

General Description

The MAX8536 evaluation (EV) kit circuit demonstrates the functionality of the MAX8536 ORing MOSFET controller that provides redundancy and fault isolation to highly reliable power systems. The MAX8536 EV kit board can operate in 5V and 3.3V systems. The EV kit is configured for 5V operation.

During startup, the EV kit monitors the voltage difference between a power supply and a power bus. Once the voltage difference is less than 0.4V (typ), the MAX8536 turns on two ORing MOSFETs, linking the power supply and power bus. Once the MOSFETs are on, the EV kit monitors the load current and voltages to protect against undervoltage (UVP), overvoltage (OVP), and reverse-current fault conditions.

The OVP and UVP thresholds are adjustable and can be disabled. The UVP threshold is set to 2.9V, and the OVP threshold is set to 5.75V. A FAULT signal output is provided for circuit monitoring.

Features

- ◆ Fault Power-Supply Isolation for 5V and 3.3V Bus
- ◆ Eliminates ORing Diode Power Dissipation
- ◆ Reverse-Current Detection
- ◆ Adjustable Undervoltage Threshold (Configured to 2.9V)
- ◆ Adjustable Overvoltage Threshold (Configured to 5.75V)
- ◆ FAULT Output Status Indicator
- ◆ Adjustable Soft-Start
- ◆ Up to 20A of Load Current
- ◆ Surface-Mount Construction
- ◆ Fully Assembled and Tested

Ordering Information

PART	TEMP RANGE	IC PACKAGE
MAX8536EVKIT	0°C to +70°C	8 μ MAX

Component List

DESIGNATION	QTY	DESCRIPTION
C1	1	0.01 μ F \pm 10%, 50V X7R ceramic capacitor (0603) TDK C1608X7R1H103K or Taiyo Yuden UMK107B103KZ
C2	1	0.1 μ F \pm 10%, 50V X7R ceramic capacitor (0603) Taiyo Yuden UMK107BJ104KA or TDK C1608X7R1H104K
C3	1	1 μ F \pm 10%, 10V X5R ceramic capacitor (0603) TDK C1608X5R1A105K
C4, C5	0	Not installed, ceramic capacitors (0805)
JU1	1	3-pin header
N1, N2	2	30V, 75A, N-MOSFETs (D ² -PAK) Fairchild FDB7045L

DESIGNATION	QTY	DESCRIPTION
PS_OUT+, PS_OUT-, VBUS+, VBUS-	4	Noninsulated banana jack connectors
R1	1	10 Ω \pm 5% resistor (0805)
R2	1	51k Ω \pm 5% resistor (0805)
R3	1	13.3k Ω \pm 1% resistor (0805)
R4, R6	2	10k Ω \pm 1% resistors (0805)
R5	1	35.7k Ω \pm 1% resistor (0805)
R7	1	24.9k Ω \pm 1% resistor (0805)
TP1	1	PC test point, red
U1	1	MAX8536EUA (8-pin μ MAX)
None	1	Shunt (JU1)
None	1	MAX8536 PC board

MAX8536 Evaluation Kit

Component Suppliers

SUPPLIER	PHONE	FAX	WEBSITE
Fairchild	888-522-5372	N/A	www.fairchildsemi.com
Taiyo Yuden	800-348-2496	847-925-0899	www.t-yuden.com
TDK	847-803-6100	847-390-4405	www.component.tdk.com
Vishay	203-268-6261	203-452-5670	www.vishay.com

Note: Please indicate that you are using the MAX8536 when contacting these component suppliers.

Quick Start

The MAX8536 EV kit is a fully assembled and tested surface-mount board. Follow the steps below for simple board operation. **Do not turn on the power supply until all connections are completed:**

- 1) Verify that a shunt is connected across pins 1 and 2 of JU1 (TIMER function set to 250kHz).
- 2) Connect the positive terminal of a 5V power supply to the PS_OUT+ banana jack. Connect the ground terminal of this power supply to the PS_OUT- banana jack.
- 3) Connect a voltmeter across the VBUS+ and VBUS- terminals.
- 4) Connect an oscilloscope to TP1 on the EV kit.
- 5) Connect a voltmeter or an oscilloscope to the FAULT pad to capture the fault signal.
- 6) Turn on the 5V power supply connected across the PS_OUT+ and PS_OUT- banana jacks.
- 7) Verify the voltmeter at VBUS+ measures 5V and TP1 measures approximately 10.5V with respect to the GND pad.
- 8) Verify FAULT measures approximately 5V.
- 9) The EV kit is ready to interface with a system for further testing.

Detailed Description

The MAX8536 EV kit circuit demonstrates the functionality of the MAX8536 ORing MOSFET controller that provides redundancy and fault isolation to highly reliable power systems. The EV kit can handle up to 20A of throughput current and can operate in 5V and 3.3V power systems. The EV kit is configured for 5V operation.

During startup the EV kit monitors the voltage difference between a power supply connected at PS_OUT+ and the power-bus VBUS+. Once the voltage drop is less than the internal threshold of 0.4V (typ) and the PS_OUT+ voltage is greater than the undervoltage

threshold, the MAX8536 controller turns on N1 and N2. Turning on the MOSFETs allows current to flow from PS_OUT+ to VBUS+ and vice versa. Once both MOSFETs are turned on, the EV kit continuously monitors the load to protect against undervoltage, overvoltage, and reverse-current fault conditions. The MAX8536 controller uses the $R_{DS(ON)}$ resistance of both MOSFETs to monitor forward- and reverse-current conditions. During undervoltage, overvoltage, or reverse-current fault conditions, a logic low is asserted on the FAULT output, and both MOSFETs are turned off to isolate PS_OUT+ from VBUS+.

The overvoltage protection (OVP) and the undervoltage protection (UVP) thresholds are adjustable and can be disabled. The UVP threshold is set to 2.9V and the OVP threshold is set to 5.75V. A FAULT signal output is provided for circuit monitoring. N1 can be shorted if OVP is disabled.

Input Voltage

The MAX8536 EV kit requires an input voltage of 4.5V to 5.5V connected across PS_OUT+ and PS_OUT- for normal operation. The MAX8536 controller starts to function when the input voltage exceeds the internal undervoltage lockout (UVLO) threshold of 2.7V (typ), but it continues to hold the GATE pin low to isolate the power supply from the live power bus until the programmed undervoltage threshold of 2.9V is exceeded. Once the input voltage exceeds the UVP threshold and the voltage difference between PS_OUT+ and VBUS+ is less than 0.4V (typ), the controller turns on the ORing MOSFETs N1 and N2 to connect the power supply to the power bus without disturbing the power bus.

GATE Drive

The GATE pin on the MAX8536 controller is the output of the internal charge pump that provides the necessary gate drive for both N1 and N2 on the EV kit. The GATE voltage can be monitored with an oscilloscope connected to TP1 on the EV kit board and should read 5.5V (typ) above the PS_OUT+ voltage. During startup, the GATE

MAX8536 Evaluation Kit

voltage ramp-up time is determined by the charge-pump frequency that is programmed by the TIMER pin. The input impedance of the measuring instrument can decrease the voltage reading at TP1 (typically 220mV for a 10MΩ device). To increase turn-off speed under fault conditions, decrease or remove C1.

TIMER

The MAX8536 controller features a dual-purpose TIMER input that sets the charge-pump frequency or functions as a logic enabler. The MAX8536 EV kit circuit provides a 3-pin jumper (JU1) to configure the TIMER pin. Place a shunt across pins 2 and 3 of JU1 to shutdown the MAX8536. Place a shunt across pins 1 and 2 of JU1 to connect the TIMER pin to ground through R7 to set the charge-pump frequency to 250kHz. Removing the shunt from JU1 leaves the TIMER pin floating and sets the charge-pump frequency to 500kHz. An open-drain/open-collector transistor can also be connected to the TIMER PC pad to control the MAX8536 controller. Assert a logic-low signal (below 0.5V) to the TIMER pad to shutdown the controller. Verify that the shunt is removed from JU1 when using an external device to control the MAX8536 (see Table 1 for JU1 configurations).

The charge-pump frequency can be reconfigured between 100kHz and 500kHz by replacing R7. Use the following equation to select a new resistor value for R7:

$$\text{Frequency} = 5 \left(100\mu\text{A} - \frac{1.25\text{V}}{R7} \right) \frac{\text{kHz}}{\mu\text{A}}$$

where Frequency is the desired charge-pump frequency.

UVP Threshold

The MAX8536 EV kit UVP threshold is programmed to 2.9V with external resistors R3 and R4. If the voltage at PS_OUT+ drops below this threshold, the MAX8536 controller turns off N1 and N2 by discharging the GATE pin and asserting a logic low on the FAULT output. The controller returns to normal operation and pulls FAULT to VBUS+ if the input voltage exceeds the UVP threshold. The UVP threshold can be reconfigured by replac-

ing R3 and R4. Use the following formula to select new resistor values:

$$R3 = R4 \left(\frac{\text{UVP}}{1.25\text{V}} - 1 \right)$$

where UVP is the desired undervoltage protection threshold and R4 is between 10kΩ and 50kΩ. The undervoltage threshold must be programmed to be greater than the internal UVLO threshold of 2.7V (typ).

Removing R3 and R4 and leaving the PC board pads open disables the UVP function.

OVP Threshold

The MAX8536 EV kit OVP threshold is programmed to 5.75V with external resistors R5 and R6. The MAX8536 controller turns off the MOSFETs, asserts a logic low on the FAULT output, and latches off when an overvoltage fault condition is detected. An overvoltage fault condition is detected only if the voltage at VBUS+ exceeds this threshold and the forward-current condition is established. The forward-current condition is defined when both MOSFETs are on and the voltage drop from PS_OUT+ to VBUS+ is greater than 0.01V (typ). A voltage drop greater than 0.01V is achieved when a minimum current of 1.6A (typ) ($1.6\text{A} \times 7\text{m}\Omega$ of $R_{DS(ON)} > 0.01\text{V}$) flows from PS_OUT+ to VBUS+. Cycling the TIMER or PS_OUT+ inputs low resets the EV kit.

The OVP threshold can be reconfigured by replacing R5 and R6. Use the following formula to select new resistor values:

$$R5 = R6 \left(\frac{\text{OVP}}{1.25\text{V}} - 1 \right)$$

where OVP is the desired overvoltage protection threshold and R4 is between 10kΩ and 50kΩ. Removing R5 and shorting R6 disables the OVP function.

When the selective OVP feature is not required, remove N1 and short its source and drain pads.

Table 1. Jumper JU1

SHUNT LOCATION	TIMER PIN	EV KIT FUNCTION
1 and 2	Connected to ground through R7	Normal Operation. Charge-pump frequency programmed to 250kHz.
2 and 3	Connected to ground	Shutdown Mode
Not Installed	Floating (connected to the TIMER PC pad*)	Normal Operation. Charge-pump frequency defaults to 500kHz.

*User can connect to the TIMER PC pad and supply a logic signal.

MAX8536 Evaluation Kit

Reverse Current

The MAX8536 controller detects reverse current during normal operation by monitoring the voltage difference between PS_OUT+ and VBUS+ using the on-resistance ($R_{DS(ON)}$) of both N-channel MOSFETs, N1 and N2. N1 and N2 have a combined on-resistance of $7m\Omega$ (typ). The MAX8536 controller detects a reverse-current fault condition when VBUS+ voltage minus PS_OUT+ voltage is greater than 0.03V (typ), after a 500ms blanking period when the gate drive first turns on. The EV kit detects a reverse-current fault condition if $4.3A$ (typ) ($4.3A \times 7m\Omega > 0.03V$) are sourced from VBUS+ to PS_OUT+. During a reverse-current condition, the MAX8536 controller turns off the MOSFETs, asserts a logic low on the FAULT output, and latches off.

FAULT Conditions

The FAULT PC pad is connected to the MAX8536 FAULT pin. The FAULT pin is pulled to VBUS+ by R2 during normal operation. During an overvoltage, undervoltage, or reverse-current fault condition, the MAX8536 enters the fault-condition state where the FAULT pin is pulled low and the GATE pin is discharged to ground. This turns off both MOSFETs. The fault condition does not latch during an undervoltage condition. The MAX8536 latches off during a reverse-current or overvoltage fault condition. Cycle the input power supply or enter shutdown mode using JU1 to clear the latch (see Table 2 for the fault states' descriptions).

Capacitors C4 and C5

Install ceramic capacitors on C4 and C5 to filter input and output bus noise. Select a ceramic capacitor with a value between $1\mu F$ and $4.7\mu F$ in a 0805 case size with a voltage rating of 6.3V (min).

Table 2. MAX8536 Fault States

FAULT STATE	CONDITIONS	MOSFETs	FAULT OUTPUT	LATCHING
Undervoltage Lockout	PS_OUT+ < 2.7V (typ)	Off	VBUS+	No
Undervoltage Protection	PS_OUT+ < 2.9V	Off	Low	No
Overvoltage Protection	VBUS+ > 5.75V and PS_OUT+ > (VBUS+) + 0.01V	Off	Low	Yes
Reverse-Current Protection	PS_OUT+ < (VBUS+) - 0.03V and MOSFETs ON for $t > 0.5s$	Off	Low	Yes

MAX8536 Evaluation Kit

Evaluates: MAX8536

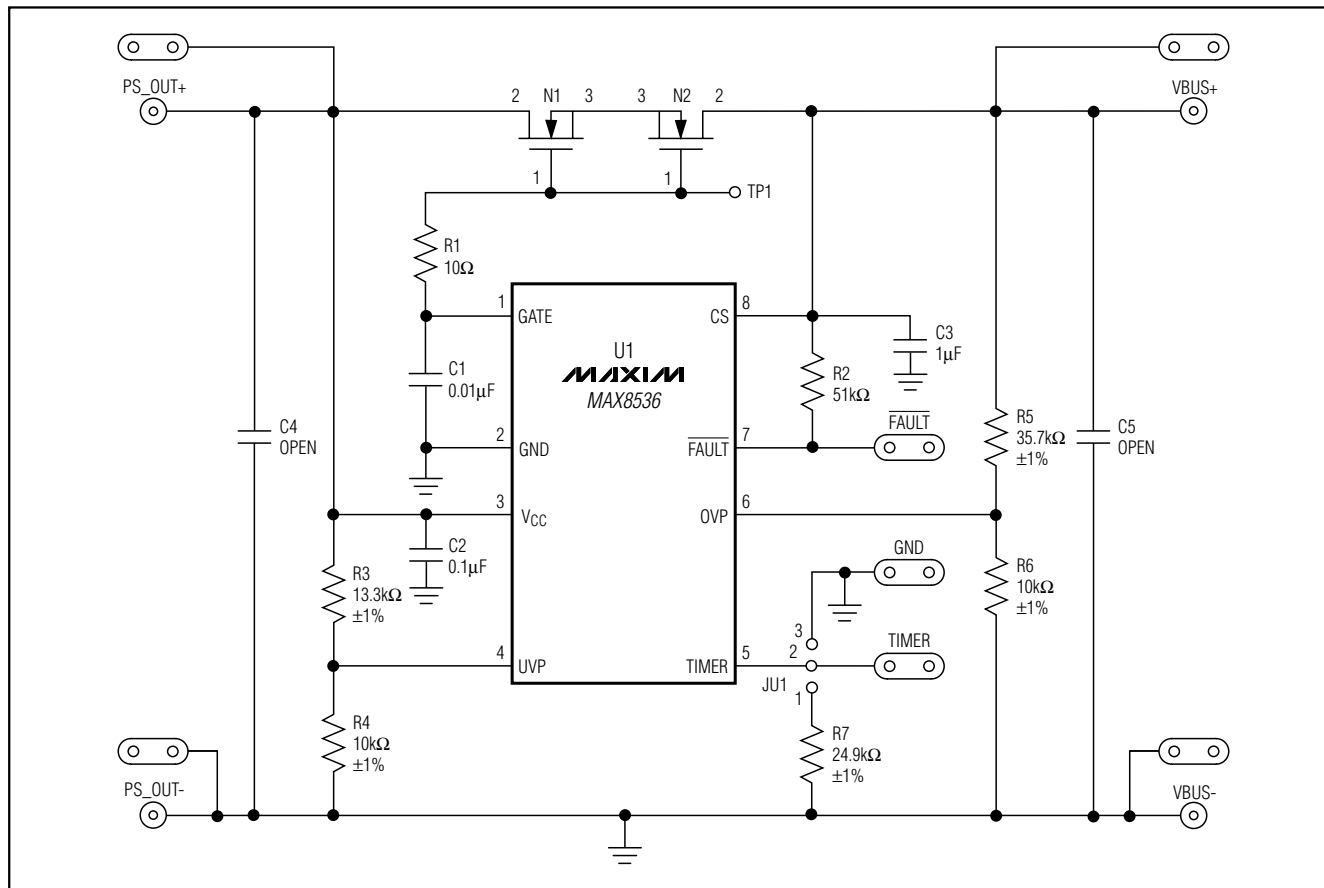

Figure 1. MAX8536 EV Kit Schematic

MAX8536 Evaluation Kit

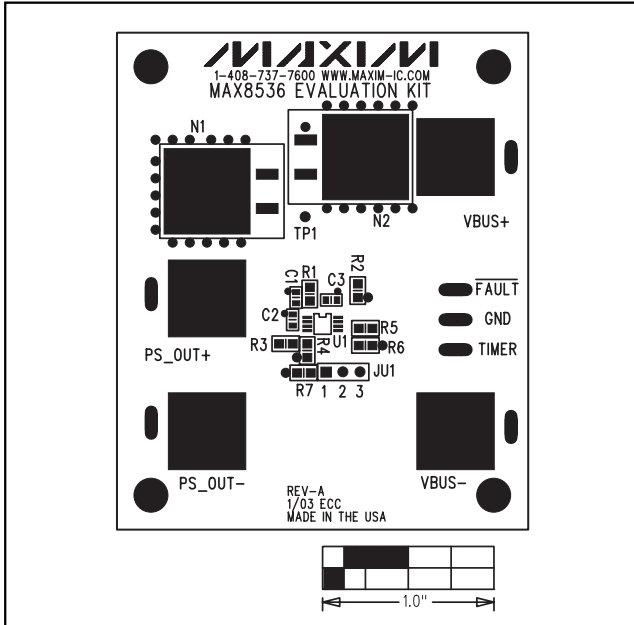

Figure 2. MAX8536 EV Kit Component Placement Guide—Component Side

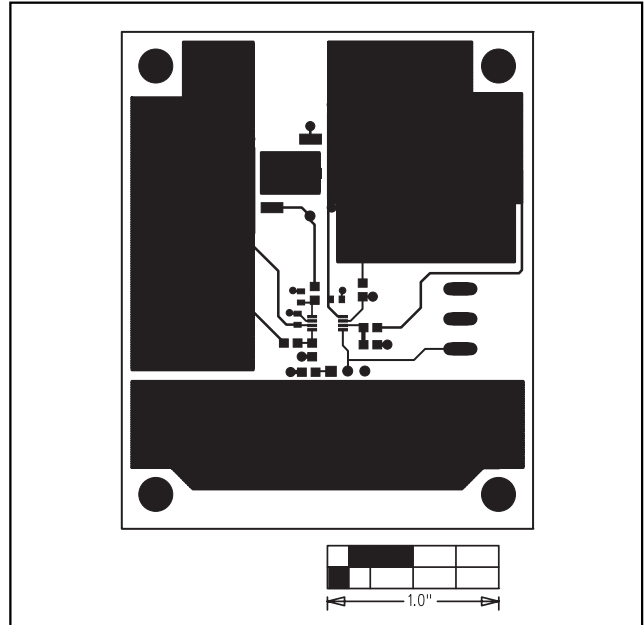

Figure 3. MAX8536 EV Kit PC Layout—Component Side

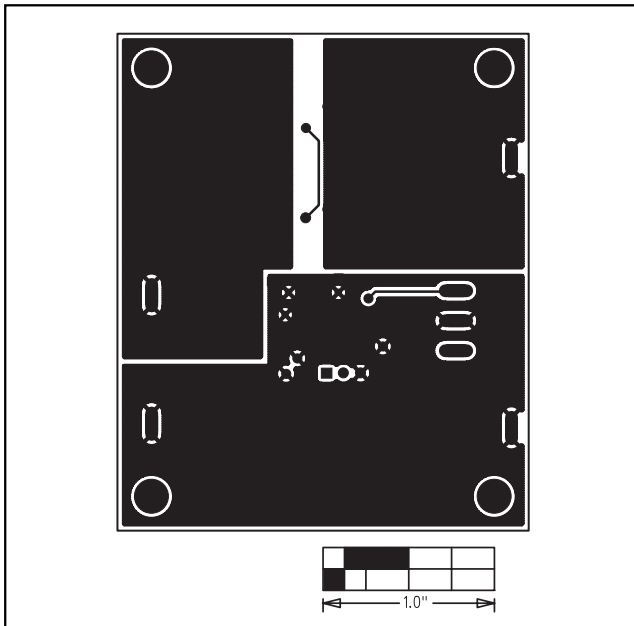

Figure 4. MAX8536 EV Kit PC Layout—Solder Side

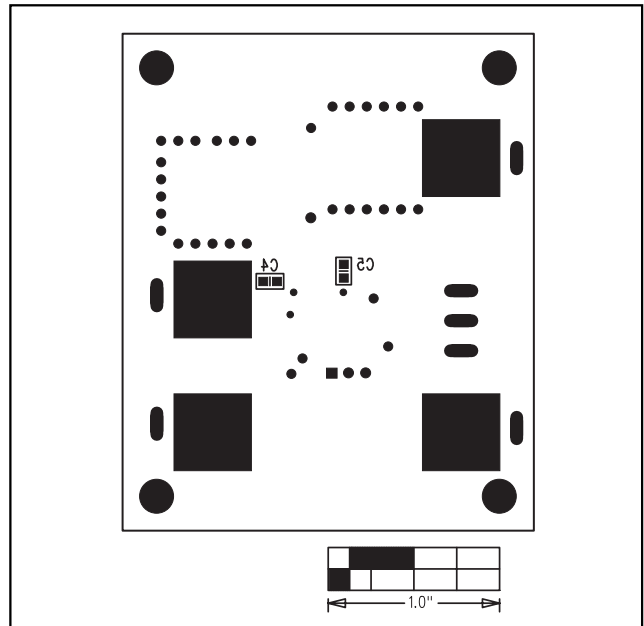

Figure 5. MAX8536 EV Kit Component Placement Guide—Solder Side

Maxim cannot assume responsibility for use of any circuitry other than circuitry entirely embodied in a Maxim product. No circuit patent licenses are implied. Maxim reserves the right to change the circuitry and specifications without notice at any time.

6 _____ **Maxim Integrated Products, 120 San Gabriel Drive, Sunnyvale, CA 94086 408-737-7600**